



DNH

ISO 9001 CERTIFIED

MH-50(T)

Commercial Audio Solutions Ltd

The Old Barn, Whitecroft Farm

Strines, Derbyshire. SK22 3AH.

Tel: 01663 767888

Email: sales@commercialaudiosolutions.com

Web: www.commercialaudiosolutions.com

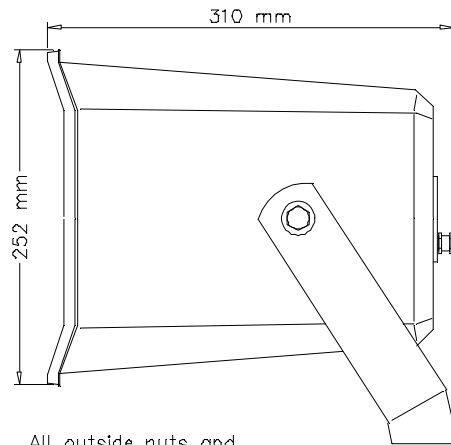
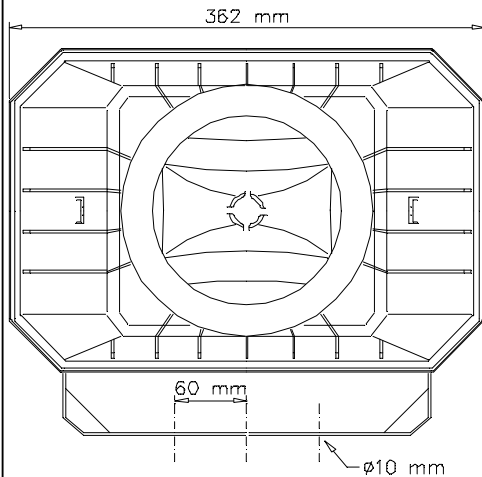

CONNECTION DIAGRAM

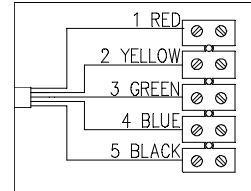

Cable gland
M-12
(2,5-6,5mm)

100V transformer Primary nominal tappings		
Red	Yellow	50,0 W
Yellow	Green	25,0 W
Green	Blue	12,5 W
Red	Green	9,0 W
Yellow	Blue	4,5 W
Red	Blue	3,0 W
Red	Black	8 Ω

Sound pressure levels at 1W/1m P-6/15B

SPL vs Freq



Specifications

Material / Color	ABS, Polypropylene / RAL 7035
Mounting	Aluminum bracket
Termination	Screw terminal
Weight w/transformer	4,1 kg
IP-rating	55
Max. / min. amb. temp	90°C / -40°C
Rated power	50W
SPL 1W/1m	104 dB
SPL rated power	121 dB
Effective freq. range	140 – 16000 Hz
Dispersion (-6dB) 1kHz / 4kHz	65° / 20°
Options	Impedances, colors, labels

Installation, Operation and Maintenance Procedures

- Unscrew lid, lead cable through cable gland and connect to terminal according to required power or 8Ω red : black.
- Tighten cable gland and fasten termination chamber lid with a torque of 1-2 Nm to assure IP grade.
- Fasten the bracket to wall or ceiling with three screws.
- To change the position of the loudspeaker, please adjust the bracket (by loosening / tightening the screws) as required.
- For optimum performance, always use the correct voltage / power and operate within the frequency limits as stated.
- Do not open loudspeaker when energized.
- This loudspeaker is supplied with two years warranty against defective workmanship.

DNH reserves the right to alter specifications without notice.

